

The innovative BGI Universal Force / Torque Gauge is the ultimate in force and torque measurement flexibility. With all the features of the Series BG, coupled with compatibility with a wide selection of interchangeable force and torque sensors, the BGI is a versatile solution for many force and torque testing applications. All sensors are fully interchangeable and do not require additional configuration or calibration.

### Series STJ

Universal torque sensors, fixed chuck



### Series STH

Universal torque sensors, interchangeable attachments



### Series STE

Wrench extension torque sensors



### Series STC

Static torque sensors



### Series STW

Torque wrenches



### Series SS

Tension / compression sensors

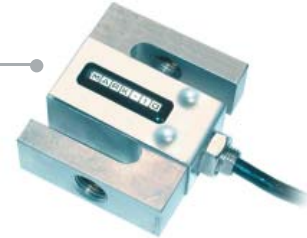

### Series SSM

Inline tension / compression sensors



### Series SJR

Miniature tension / compression sensors



### Series SBC

Compact compression sensors



### Series SHP

Ergonomics testing push / pull sensors



### Series STB

Closure torque sensors



## BGI Specifications

Accuracy:	±0.1% of full scale ±1 digit + sensor
Sampling rate:	65 readings/s
Display rate:	2.5 updates/s in normal mode / 65 updates/s in peak mode
Power:	AC or rechargeable battery with Intelligent Power Management System (IPM), a 3-step system that warns the user via a "LO BAT" indicator and then powers off the gauge.
Battery life:	8-10 hours of continuous use
Selectable units of measurement:	lb, kg, g, N, ozin, lbFin, kgFmm, kgFm, Ncm, Nm (depending on sensor)
Outputs:	Standard
RS-232	Fully configurable up to 9600 baud. Includes Gauge Control Language (GCL) for full computer control of all functions.
Mitutoyo (Digimatic)	Serial BCD suitable for all Mitutoyo SPC-compatible devices
Analog	±1 VCD, ±0.25% of full scale at capacity. + CW, - for CCW.
General purpose I/O	Three open collector outputs and one input (utilizing Mitutoyo lines)
Set points	Three open collector lines (utilizing Mitutoyo lines)
Configurable settings:	Analog filters, digital filters, RS-232, outputs selection (other than RS-232), automatic output (RS-232), automatic shutoff, initial (default), averaging mode, calibration
Weight (gauge only):	0.9 lb [0.4 kg]
Environmental requirements:	40° F - 100° F [5° C - 45° C], <96% humidity (non-condensating)
Thermal effects:	Zero: 0.03% of full scale/°C, Span: 0.01% of full scale/°C for all remote sensors
Housing construction:	Aluminum
Warranty	3 years (see individual statement for further details)

## Features

Interchangeable remote force & torque sensors	
Data outputs	RS-232, Mitutoyo (Digimatic), and analog outputs. Automatic timed output (RS-232) included.
Set points	Programmable high and low force set points for triggering external devices (ex. motorized test stand, alarm, etc).
Data averaging	Calculates average force over a specified time (programmable)
External trigger	Useful for contact or switch activation force testing and data capture

## Optional Equipment

Output cables	Various data output cables are available
Hi / lo limits indicator 11-1022	Set limit conditions for a test - the indicator will display red lights for high and low limits, and a green light to indicate passing.
Overload protection module 11-1042	Protects the remote sensor against overloads during motorized tests, adjustable from 10 - 150% of the sensor's full capacity. For use with motorized test stands.
Set point cable 09-1090	Stops test stand motion at programmable high and low set points for tension and compression or CW and CCW. For use with motorized test stands.
Test stand mounting kit AC1004	Allows the BGI to be mounted to TS-Series force or torque test stand
Tabletop stand AC1008	Includes gauge mounting screws, and holes for mounting to a workbench. Display angle can be adjusted.

## Dimensions

in [mm]

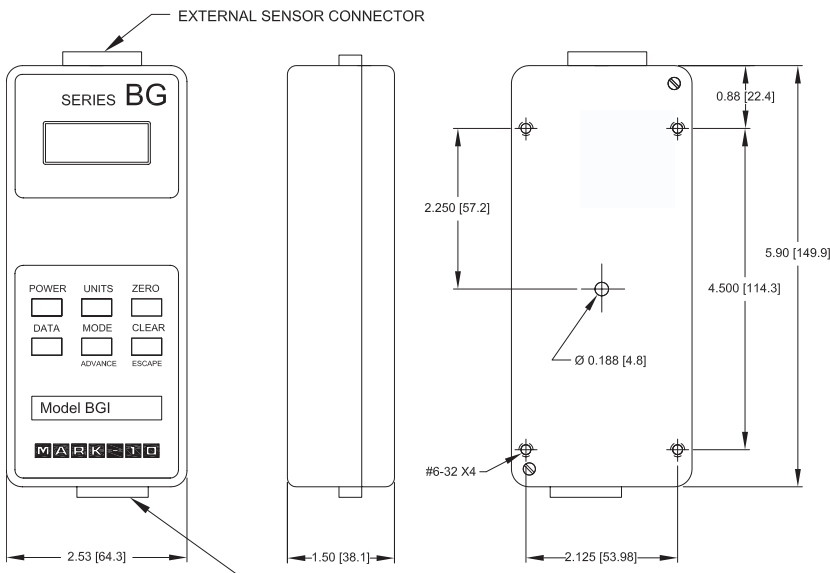

## Ordering Information

Model No.	Description
BGI	Universal Force / Torque Gauge, 110V
BGIE	Universal Force / Torque Gauge, 220V

The BGI and all sensors are supplied with an NIST-traceable certificate of calibration

## Universal Torque Sensors Series STJ



Measure bi-directional torque for a wide variety of applications. Contains a chuck for up to 1/2" diameter samples. The sensor can be used as a hand held device, or mounted to a test stand. Capacities available from 10 ozFin to 100 lbFin.

### Specifications

Chuck capacity: STJ10Z - STJ50Z: 0.38 in [9.5 mm]  
 STJ12 - STJ100: 0.5 in [12.7 mm]  
 Accuracy: ±0.35% of full scale + BGI  
 Safe overload: STJ10Z - STJ50Z: 300% of full scale  
 STJ12 - STJ100: 150% of full scale  
 Weight: 1.4 lb [0.6 kg]

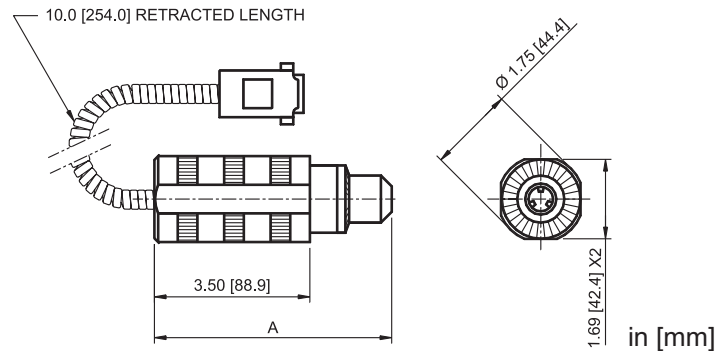

Model No.	A
STJ10Z - STJ50Z	4.82 [122.4]
STJ12 - STJ100	5.19 [131.8]

### Ordering Information

Model No.	Capacity x resolution
STJ10Z	10 x 0.01 ozFin, 7 x 0.005 kgFmm, 7 x 0.005 Ncm
STJ20Z	20 x 0.02 ozFin, 14 x 0.01 kgFmm, 14 x 0.01 Ncm
STJ50Z	50 x 0.05 ozFin, 36 x 0.05 kgFmm, 35 x 0.05 Ncm
STJ12	12 x 0.01 lbFin, 140 x 0.1 kgFmm, 135 x 0.1 Ncm
STJ50	50 x 0.05 lbFin, 580 x 0.5kgFmm, 570 x 0.5 Ncm
STJ100	100 x 0.1 lbFin, 1150 x 1 kgFmm, 1150 x 1 Ncm

## Universal Torque Sensors Series STH



A great solution for general bi-directional torque testing applications with several different sample sizes. Three interchangeable chuck capacities and bit holder are available. The STH has superb overload protection and is available in capacities from 10 ozFin to 100 lbFin.

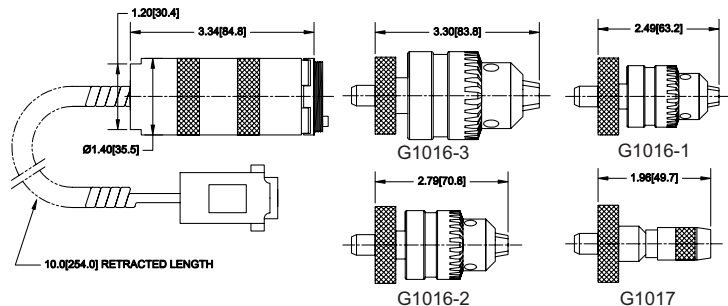

in [mm]

### Specifications

Chuck and bit capacities: G1016-1: 0.028 - 0.25 in [0.7 - 6.3 mm]  
 G1016-2: 0.062 - 0.375 in [1.6 - 9.5 mm]  
 G1016-3: 0.078 - 0.5 in [2.0 - 12.7 mm]  
 G1017: 0.25 in [6.3 mm] hex  
 Accuracy: ±0.2% of full scale + BGI  
 Safe overload: STH10Z - STH20Z: 300% of full scale  
 STH12 - STH50: 200% of full scale  
 STH100: 150%  
 Weight: From 1.4 lb [0.6 kg]

### Ordering Information

Model No.	Capacity x resolution
STH10Z	10 x 0.01 ozin, 7 x 0.005 kgFmm, 7 x 0.005 Ncm
STH20Z	20 x 0.02 ozin, 14 x 0.01 kgFmm, 14 x 0.01 Ncm
STH50Z	50 x 0.05 ozin, 36 x 0.05 kgFmm, 35 x 0.05 Ncm
STH12	12 x 0.01 lbFin, 140 x 0.1 kgFmm, 135 x 0.1 Ncm
STH50	50 x 0.05 lbFin, 580 x 0.5 kgFmm, 570 x 0.5 Ncm
STH100	100 x 0.1 lbFin, 1150 x 1 kgFmm, 1150 x 1 Ncm
G1016-1	Jacobs chuck for STH, 0.028"-0.25"
G1016-2	Jacobs chuck for STH, 0.062"-0.375"
G1016-3	Jacobs chuck for STH, 0.078"-0.5"
G1017	Bit holder for STH, 1/4" hex

## Wrench Extension Torque Sensors Series STE



Convert any wrench to a torque tool with this sensor, or use it as a component of a torque testing system. Capacities available from 20 lbFin to 5,000 lbFin.

### Specifications

Accuracy:  $\pm 0.6\%$  of full scale + BGI  
 Safe overload: 150% of full scale  
 Weight: 0.6 - 2.0 lb [0.3 - 0.9 kg], depending on model

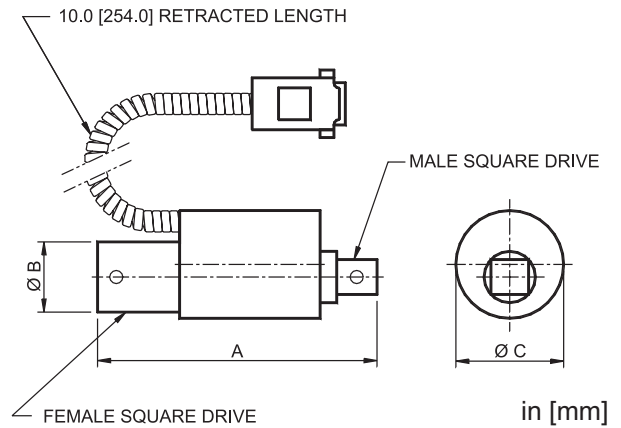

### Ordering Information

Model No.	Capacity x resolution
STE20	20 x 0.02 lbFin, 230 x 0.2 kgFmm, 220 x 0.2 Ncm
STE50	50 x 0.05 lbFin, 580 x 0.5 kgFmm, 570 x 0.5 Ncm
STE100	100 x 0.1 lbFin, 1150 x 1 kgFmm, 1150 x 1 Ncm
STE200	200 x 0.2 lbFin, 2300 x 2 kgFmm, 2200 x 2 Ncm
STE400	400 x 0.5 lbFin, 4600 x 5 kgFmm, 4500 x 5 Ncm
STE1000	1000 x 1 lbFin, 11500 x 10 kgFmm, 11000 x 10 Ncm
STE5000	5000 x 5 lbFin, 55 x 0.05 kgFm, 550 x 0.5 Nm

Model No.	A	ØB	ØC	Drive Size
STE20 - STE100	1.88 [47.8]	0.56 [14.2]	1.00 [25.4]	1/4"
STE200 - STE400	3.00 [76.2]	0.73 [18.5]	1.12 [28.6]	3/8"
STE1000	3.50 [88.9]	0.98 [24.9]	1.25 [31.8]	1/2"
STE5000	5.00 [127.0]	1.48 [37.6]	2.0 [50.8]	3/4"

## Static Torque Sensors Series STC



Calibrate torque tools, or use it as a component of a torque testing system. Tapped holes on every surface allow for easy mounting to a work bench or fixture. Capacities available from 10 ozFin to 100 lbFin.

### Specifications

Accuracy:  $\pm 0.35\%$  of full scale + BGI  
 Safe overload: STC10Z - STC50Z: 300% of full scale  
 STC12 - STC100: 150% of full scale  
 Weight: 1.2 lb [0.5 kg]

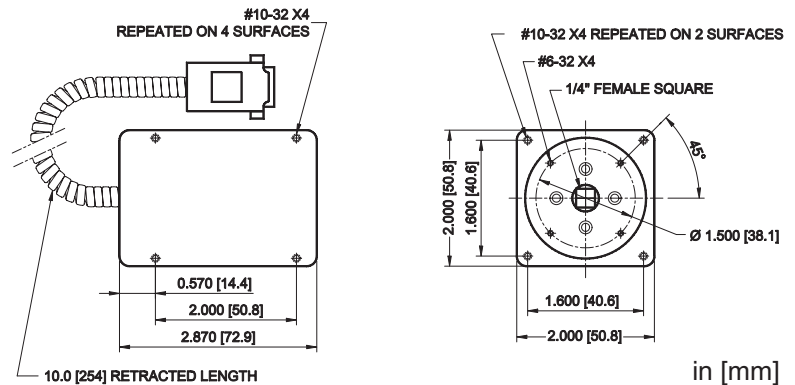

### Ordering Information

Model No.	Capacity x resolution
STC10Z	10 x 0.01 ozFin, 7 x 0.005 kgFmm, 7 x 0.005 Ncm
STC20Z	20 x 0.02 ozFin, 14 x 0.01 kgFmm, 14 x 0.01 Ncm
STC50Z	50 x 0.05 ozFin, 36 x 0.05 kgFmm, 35 x 0.05 Ncm
STC12	12 x 0.01 lbFin, 140 x 0.1 kgFmm, 135 x 0.1 Ncm
STC50	50 x 0.05 lbFin, 580 x 0.5 kgFmm, 570 x 0.5 Ncm
STC100	100 x 0.1 lbFin, 1150 x 1 kgFmm, 1150 x 1 Ncm

## Closure Torque Sensors Series STB



Ideal for testing torque on bottle caps and containers. Reversible jaws or movable posts, depending on model, effectively accommodate a variety of shapes and sizes. Capacities available from 10 ozFin to 100 lbFin.

### Specifications

Accuracy:  $\pm 0.7\%$  of full scale + BGI  
 Safe overload: STB10Z - STB50Z: 300% of full scale  
 STB12 - STB100: 150% of full scale  
 Weight: STB10Z - STB50Z: 2.2 lb [1.0 kg]  
 STB12 - STB100: 5.4 lb [2.5 kg]

### Ordering Information

Model No.	Capacity x resolution
STB10Z	10 x 0.01 ozFin, 7 x 0.005 kgFmm, 7 x 0.005 Ncm
STB20Z	20 x 0.02 ozFin, 14 x 0.01 kgFmm, 14 x 0.01 Ncm
STB50Z	50 x 0.05 ozFin, 36 x 0.05 kgFmm, 35 x 0.05 Ncm
STB12	12 x 0.01 lbFin, 140 x 0.1 kgFmm, 135 x 0.1 Ncm
STB50	50 x 0.05 lbFin, 580 x 0.5 kgFmm, 570.0 x 0.5 Ncm
STB100	100 x 0.1 lbFin, 1150 x 1 kgFmm, 1150 x 1 Ncm

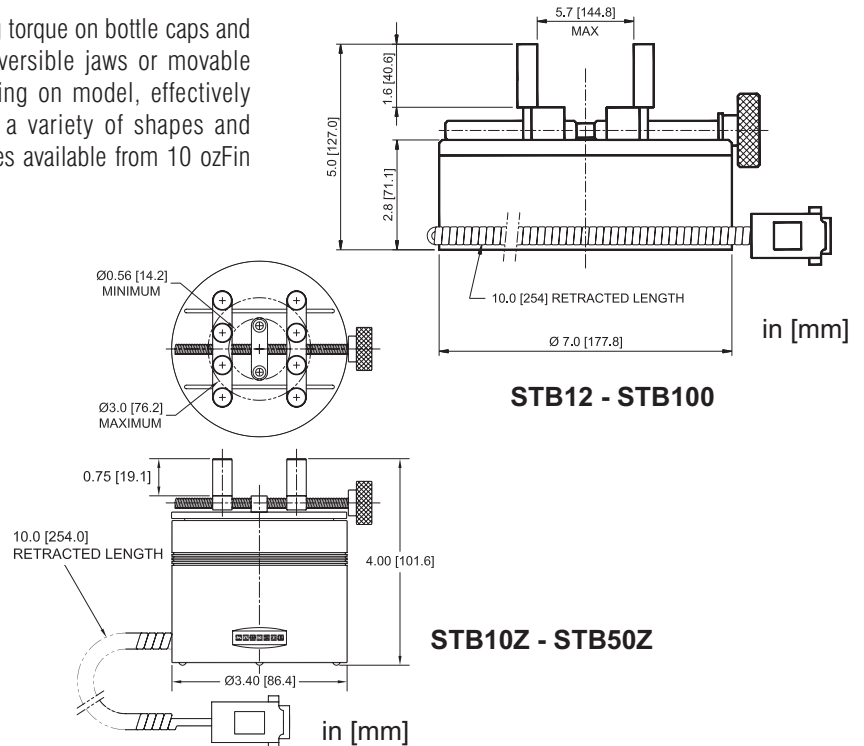

## Torque Wrenches Series STW



Ideal for testing application and removal torque on bolts and other fasteners, with numerous applications in the automotive, aerospace, and other industries. Capacities available from 100 lbFin to 1000 lbFin.

### Specifications

Accuracy:  $\pm 0.6\%$  of full scale + BGI  
 Safe overload: 150% of full scale  
 Weight: STW100: 1.9 lb [0.9 kg]  
 STW500: 2.2 lb [1.0 kg]  
 STW1000: 2.8 lb [1.3 kg]

### Ordering Information

Model No.	Capacity x resolution
STW100	100 x 0.1 lbFin, 1150 x 1 kgFmm, 1150 x 1 Ncm
STW500	500 x 0.5 lbFin, 5000 x 5 kgFmm, 5000 x 5 Ncm
STW1000	1000 x 1 lbFin, 11500 x 10 kgFmm, 11000 x 10 Ncm

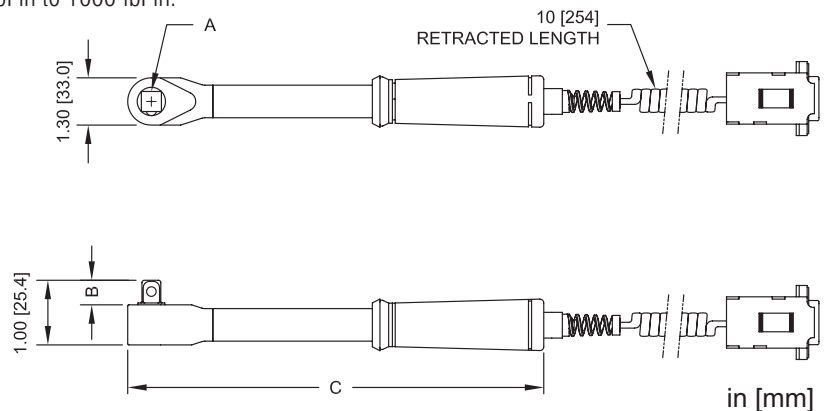

Model No.	A	B	C
STW100	3/8" SQUARE	0.5 [12.7]	11.0 [280.0]
STW500	3/8" SQUARE	0.5 [12.7]	14.0 [355.0]
STW1000	1/2" SQUARE	0.7 [17.8]	20.0 [508.0]

## Tension / Compression Sensors Series SS



A rugged sensor for measuring tensile and compressive force of up to 10,000 lbF. Durable S-Beam design with threaded holes on two sides allows for many applications and setups. Steel construction ensures many years of use.

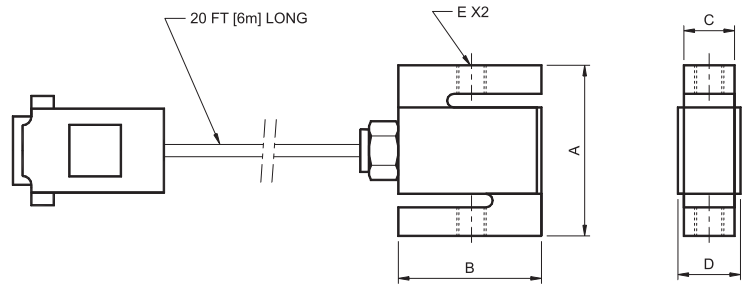

in [mm]

### Specifications

Accuracy:  $\pm 0.15\%$  of full scale + BGI  
 Safe overload: 150% of full scale  
 Weight: From 1.9 - 3.0 lb [0.9 - 1.4 kg]

### Ordering Information

Model No.	Capacity x resolution
SS50	50 x 0.02 lbF, 25 x 0.01 kgF, 250 x 0.1 N
SS100	100 x 0.05 lbF, 50 x 0.02 kgF, 500 x 0.2 N
SS200	200 x 0.1 lbF, 100 x 0.05 kgF, 1000 x 0.5 N
SS500	500 x 0.2 lbF, 250 x 0.1 kgF, 2500 x 1 N
SS1000	1000 x 0.5 lbF, 500 x 0.2 kgF, 5000 x 2 N
SS2000	2000 x 1 lbF, 1000 x 0.5 kgF, 10000 x 5 N
SS5000	5000 x 2 lbF, 2500 x 1 kgF, 25 x 0.01 kN
SS10000	10000 x 5 lbF, 5000 x 2 kgF, 50 x 0.02 kN

Model No.	A	B	C	D	E
SS50	2.40 [61.0]	2.00 [50.8]	0.46 [11.7]	0.65 [16.5]	1/4-28 UNF
SS100			0.71 [18.0]	0.90 [22.9]	1/2-20 UNF
SS200					
SS500					
SS1000	3.90 [99.1]	3.00 [76.2]	0.96 [24.4]	1.15 [29.2]	3/4-16 UNF
SS2000					
SS5000					
SS10000					

## Inline Tension / Compression Sensors Series SSM



Measures tensile and compressive loads for a wide variety of applications, available in capacities from 0.25 lbF to 100 lbF. Threaded holes on two sides can accept a variety of hooks and implements, making this sensor particularly well suited for inline tests.

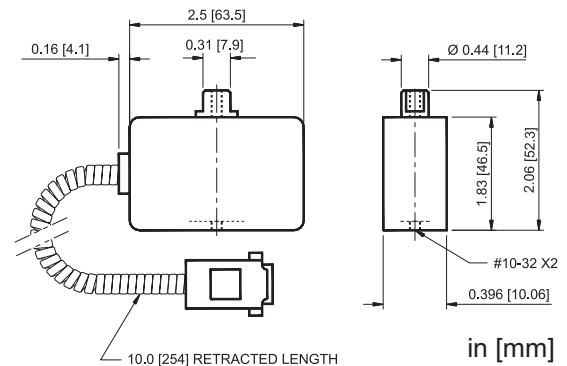

in [mm]

### Specifications

Accuracy:  $\pm 0.15\%$  of full scale + BGI  
 Safe overload: SSM025 - SSM2: 200% of full scale  
 SSM5 - SSM100: 150% of full scale  
 Weight: 0.4 lb [0.2 kg]

### Ordering Information

Model No.	Capacity x resolution
SSM025	0.25 X 0.0001 lbF, 100 x 0.05 gF, 1 x 0.0005 N
SSM05	0.5 x 0.0002 lbF, 250 x 0.1 gF, 2.5 x 0.001 N
SSM2	2 x 0.001 lbF, 1 x 0.0005 kgF, 10 x 0.005 N
SSM5	5 x 0.002 lbF, 2.5 x 0.001 kgF, 25 x 0.001 N
SSM10	10 x .005 lbF, 5 x 0.002 kgF, 50 x 0.02 N
SSM20	20 x 0.01 lbF, 10 x 0.005 kgF, 100 x 0.05 N
SSM50	50 x 0.02 lbF, 25 x 0.01 kgF, 250 x 0.1 N
SSM100	100 x 0.05 lbF, 50 x 0.02 kgF, 500 x 0.2 N

## Miniature Tension / Compression Sensors Series SJR

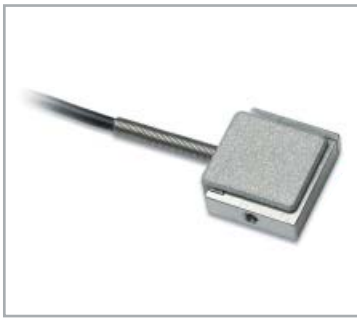

Extremely compact force measurement sensor for tensile and compressive loads in applications with limited space. Capacities available from 0.25 lb to 100 lbF. The sensors include threaded holes on two sides for the mounting of attachments or implements.

### Specifications

Accuracy: ±0.2% of full scale + BGI  
 Safe overload: 200% of full scale  
 Weight: 0.015 lb [0.007 kg]

### Ordering Information

Model No.	Capacity x resolution
SJR025	0.25 X 0.0001 lbF, 100 x 0.05 gF, 1 x 0.0005 N
SJR05	0.5 x 0.0002 lbF, 250 x 0.1 gF, 2.5 x 0.001 N
SJR2	2 x 0.001 lbF, 1 x 0.0005 kgF, 10 x 0.005 N
SJR5	5 x 0.002 lbF, 2.5 x 0.001 kgF, 25 x 0.001 N
SJR10	10 x .005 lbF, 5 x 0.002 kgF, 50 x 0.02 N
SJR20	20 x 0.01 lbF, 10 x 0.005 kgF, 100 x 0.05 N
SJR50	50 x 0.02 lbF, 25 x 0.01 kgF, 250 x 0.1 N
SJR100	100 x 0.05 lbF, 50 x 0.02 kgF, 500 x 0.2 N

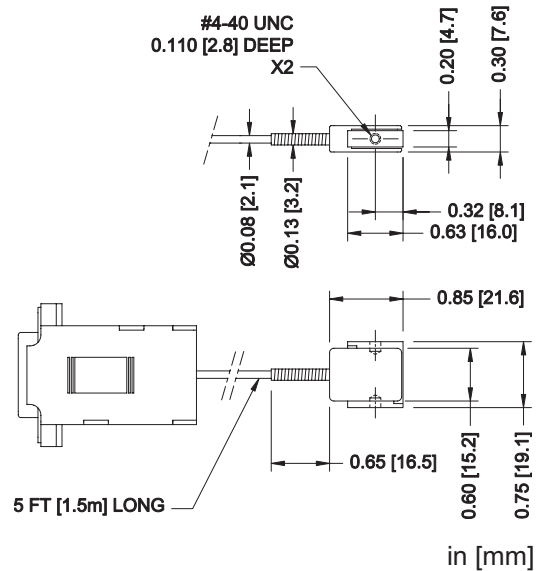

## Compact Compression Sensors Series SBC



Button type sensor for compressive loads of up to 10,000 lbF. Compact and rugged, the SBC is ideal for heavy duty applications with space constraints.

### Specifications

Accuracy: ±0.5% of full scale + BGI  
 Safe overload: 150% of full scale  
 Weight: From 0.4 lb [0.2 kg]

### Ordering Information

Model No.	Capacity x resolution
SBC100	100 x 0.05 lbF, 50 x 0.02 kgF, 500 x 0.2 N
SBC200	200 x 0.1 lbF, 100 x 0.05 kgF, 1000 x 0.5 N
SBC500	500 x 0.2 lbF, 250 x 0.1 kgF, 2500 x 1 N
SBC1000	1000 x 0.5 lbF, 500 x 0.2 kgF, 5000 x 2 N
SBC2000	2000 x 1 lbF, 1000 x 0.5 kgF, 10000 x 5 N
SBC5000	5000 x 2 lbF, 2500 x 1 kgF, 25 x 0.01 kN
SBC10000	10000 x 5 lbF, 5000 x 2 kgF, 50 x 0.02 kN

SBC100 - SBC2000:

SBC5000 - SBC10000:

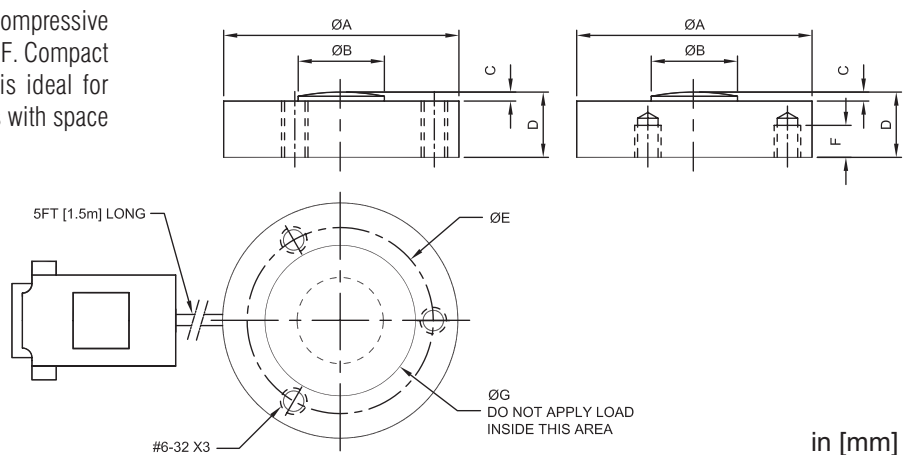

Model No.	ØA	ØB	C	D	ØE	F	ØG
SBC100 - SBC2000	1.23 [31.3]	0.32 [8.1]	0.05 [1.3]	0.39 [9.9]	1.0 [25.4]	-	0.83 [21.1]
SBC5000 - SBC10000	1.48 [37.6]	0.43 [10.9]	0.07 [1.8]	0.62 [15.8]	1.25 [31.8]	0.25 [6.4]	1.08 [27.4]

## Pull / Push Sensors Series SHP



Fully enclosed sensor for pull / push testing. Useful in ergonomics testing, workplace safety testing, and general lifting or push/pull requirements. For up to 500 lbF of force.

### Specifications

Accuracy:  $\pm 0.15\%$  of full scale + BGI  
 Safe overload: 150% of full scale

### Ordering Information

Model No.	Capacity x resolution
SHP500	500 x 0.2 lbF, 250 x 0.1 kgF, 2500 x 1 N

