



Series TT01 Cap Torque Testers are designed to measure application and removal torque of bottle caps up to 100 lbFin [11.5 Nm]. Adjustable posts effectively grip a broad range of container shapes and sizes, while optional flat and adjustable jaws are available for unique profiles. A rugged aluminum design, and simple, intuitive operation allow for use in laboratory and production environments.

Class-leading accuracy of $\pm 0.3\%$ and blazingly fast sampling rate of 7,000 Hz ensure reliable and consistent test results, even in quick-action applications.

The TT01 includes a range of sophisticated productivity-enhancing features, including USB, RS-232, Mitutoyo, and analog outputs, automatic data output and zeroing upon cap removal, memory storage for 1,000 readings, pass/fail indicators and outputs, and more. Password protection is provided to prevent unauthorized changes to settings and calibration.

Series TT01 testers include MESUR™ Lite data acquisition software. MESUR™ Lite tabulates continuous or single point data. Data stored in the TT01's memory can also be downloaded in bulk. One-click export to Excel allows for further data manipulation.

MESUR Lite data acquisition software is included with Series TT01 testers

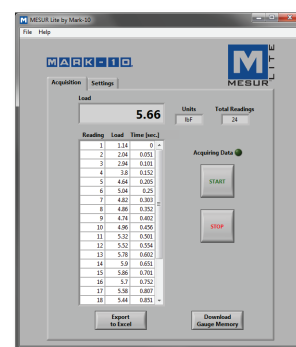

Features

- Moveable posts and optional jaws accommodate a wide range of sample shapes and sizes
- USB, RS-232, Mitutoyo, and analog outputs
- Automatic output, data storage, and zeroing upon bottle cap removal helps automate testing processes
- 1,000-point data memory with statistics and outputs
- Password protection prevents unauthorized changes
- Programmable set point indicators and outputs for pass/fail determination
- High-speed 7,000 Hz sampling rate accurately captures peak torque values
- Configurable audio alarms and key tones
- 5 selectable units of measurement
- MESUR™ Lite data collection software included

Controls & Indicators

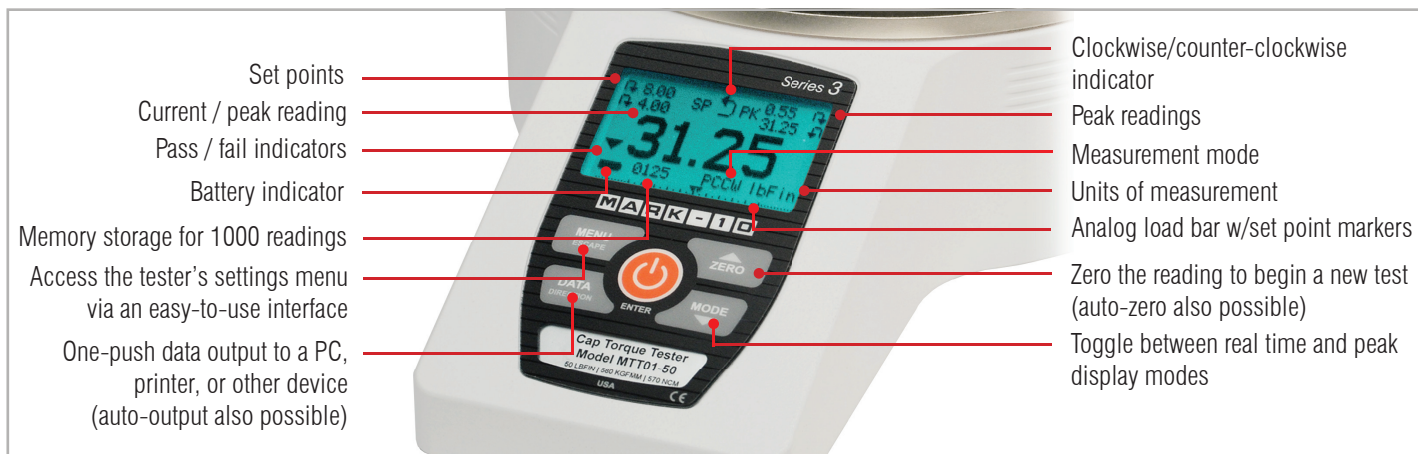

Optional Items



CT001

Flat jaws

Set of rubber jaws for gripping square or odd shaped containers.



CT002

Carrying case

Provides storage space for the TT01 tester, gripping jaws, AC adapter, and accessories.

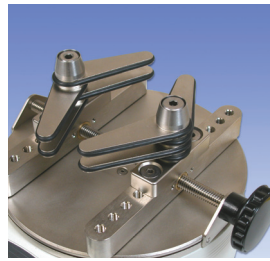

CT003

Adjustable jaws

Rubber-edged arms may be independently repositioned to accommodate unique samples.

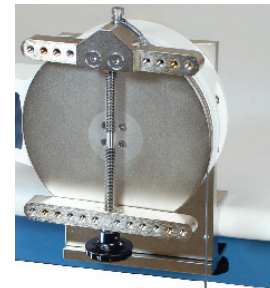

AC1036

Calibration kit

Complete set of brackets, cable, AC1036 and hardware for calibration of any Series TT01 torque tester. Weights not available from Mark-10.



Specifications

Accuracy:	±0.3% of full scale
Sampling Rate:	7,000 Hz
Power:	AC or rechargeable battery. Multi-step low battery indicator is displayed, tester shuts off automatically when power is too low.
Battery life:	Backlight on: up to 7 hours of continuous use Backlight off: up to 24 hours of continuous use
Units:	ozFin, lbFin, lbFft, Nm, Ncm
Outputs:	USB / RS-232: Configurable up to 115,200 baud. Mitutoyo: Serial BCD suitable for all Mitutoyo SPC-compatible devices. Analog: ±1 VCD, ±0.25% of full scale at capacity. General purpose: Three open drain outputs, one input. Set points: Three open drain lines.
Configurable settings:	Digital filters, outputs, automatic shutoff, default settings, key tones, backlight, audio alarms, passwords, calibration
Safe overload:	150% of full scale (display shows "OVER" at 110% and above)
Weight:	8.4 lb [3.8 kg]
Included items:	Universal voltage AC adapter, battery, quick-start guide, USB cable, resource CD (USB driver, MESUR™ Lite software, MESUR™ gauge DEMO software, and user's guide), and NIST-traceable certificate of calibration with data.
Warranty:	3 years (see individual statement for further details)

Dimensions in [mm]

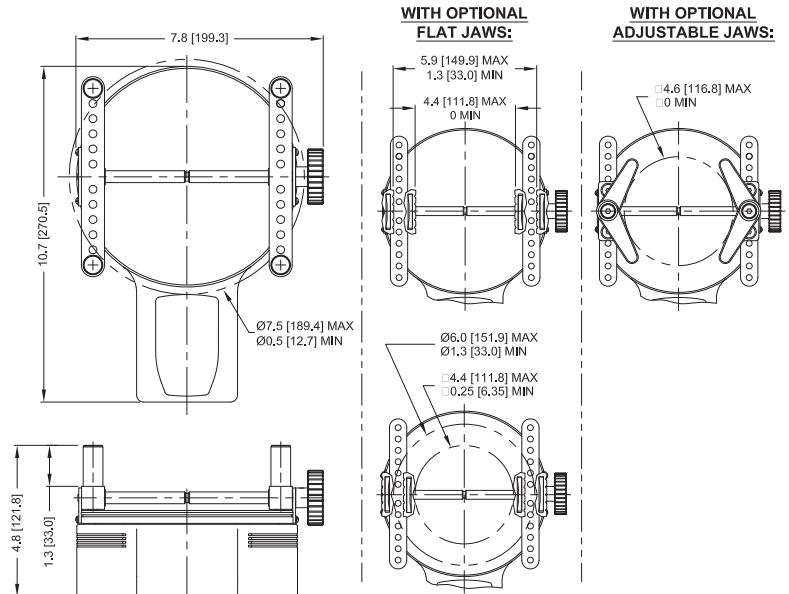

Capacity x Resolution

Model No.	ozFin	lbFin	lbFft	Ncm	Nm
MTT01-12	192 x 0.1	12 x 0.005	1 x 0.0005	135 x 0.1	1.35 x 0.001
MTT01-50	320 x 0.2	50 x 0.02	4 x 0.002	570 x 0.5	5.7 x 0.005
MTT01-100	800 x 0.5	100 x 0.05	8 x 0.005	1150 x 0.5	11.5 x 0.005

All models include 110V AC adapters. Add suffix 'E' for euro plug (220V), 'U' for UK plug (220V), or 'A' for Australian plug (220V).

Ex: MTT01-12E, MTT01-50U, MTT01-100A